



NOVARENT

LOCATION ET VENTE DE MATÉRIEL DE MESURE

BOREHOLE EXTENSOMETER SYSTEM (BHE) WITH VIBRATING WIRE/ POTENTIOMETRIC SENSORS

MODEL EDS-71V/P



Contents

1	INTRODUCTION	1
1.1	Applications	1
1.2	Measurement method	1
1.3	Conventions used in this manual	2
1.4	How to use this manual	2
2	BOREHOLE EXTENSOMETER (BHE)	4
2.1	General Description	4
2.1.1	Reference head assembly	4
2.1.2	Displacement sensor	4
2.1.3	Connecting rod assembly	6
2.1.4	Anchor	7
2.2	Accessories	8
2.2.1	Junction box	8
2.2.2	Cable	8
3	INSTALLATION OF SINGLE POINT BOREHOLE EXTENSOMETER	9
3.1	Site preparation before installation	9
3.2	Check sensor before installation	9
3.3	Procedure	12
3.4	Tools & accessories required for installation	17

1 INTRODUCTION

Encardio-rite model EDS-71V single point borehole extensometer using vibrating wire sensors is a precision instrument designed to help civil engineers and geologists in measurement of deformation of rock mass and adjacent or surrounding soil. Together with anchor bolt load cells and tape extensometer, it is an essential piece of equipment for investigation and monitoring of foundations, slopes & embankments and for studying behaviour of rock around underground cavities, tunnels and mines.

NOTE: Same manual to be used for model EDS-71P single point borehole extensometer using potentiometric sensors. Make special note of the following:

- Diameter of model EDE-PXX potentiometric sensor is 16 mm whereas diameter of Model EDE-VXX is 12.7 mm. This requires adaptor cum guide plate (6) and link plate (16) in figure 2.2 to be different in the two assemblies.
- Manual readout unit for EDE-PXX is model EDI-53P, whereas for model EDE-VXX is model EDI-51V.
- For Sample test certificate of model EDE-PXX refer to page 3-3. Sample test certificate for model EDE-VXX is given on page 3-2.

1.1 Applications

- To determine how roof or wall of mine, underground cavity or tunnel behaves during excavation.
- To study effectiveness of the roof/wall support system of a mine, underground cavity or tunnel.
- To predict potential roof or wall falls before they actually occur. Roof or wall falls in underground cavities are almost invariably preceded by measurable sags as the strata opens up and the movement usually occurs at an increasing rate as fall conditions are approached. Unsuspected roof and wall falls may result in serious accidents and may require costly patch-up and repair operations.
- To measure and monitor movements in slopes and foundations due to excavation of underground cavities or due to construction of heavy structures like concrete, rockfill, masonry or earth dams over the foundation.
- Suitable for upward or downward sloping hole using fibreglass or stainless steel AISI-410 connecting rods.

Model EDS-71V/P has following options:

- Required borehole for installation of single point extensometers is ϕ 50 mm. Diameter at the mouth of borehole is increased to 63 mm (300 mm depth for 50 mm displacement sensor or 430 mm depth for 100 mm displacement sensor and 560 mm for 150 mm displacement sensor).
- The displacement is measured electronically by using a vibrating wire displacement transducer model EDE-VXX and a readout system model EDI-51V or data acquisition system model EDAS-10. The displacement is measured using potentiometric sensor model EDE-PXX with an indicator EDI- 53P

1.2 Measurement method

The displacement is measured electronically by using a vibrating wire displacement transducer model EDE-VXX and Potentiometric displacement transducer model EDE-PXX with read out system model EDI-51V and EDI-53P respectively or data acquisition system model EDAS-10.

Dimensional details of sensor

<u>Displacement</u>	<u>Overall length of VW sensor (in closed position)</u>	<u>Overall length of Pot. sensor (in closed position)</u>
50 mm	290 mm	325 mm
100 mm	420 mm	425 mm
150 mm	550 mm	525 mm

The sensor shaft is fixed to female thread in connecting rod through a sensor lock nut (18), link plate (16), sensor tightening nut (17) and a reference button (15) - refer to figures 2.1 and 2.2. The outside body of sensor is fixed to a adopter cum guide plate (6) in the flanged housing at the face of the borehole. The system is rugged and is protected by a protecting cover (19). Flange assembly (5) .Nipple is an integral part of flanged housing (22) through which cable for sensors can be taken to a junction box (23) and then through a multi-core cable to any distant location.

NOTE: Encardio-rite uses the convention that depth of anchor is calculated as the distance from the mouth of hole to near end of anchor.

CAUTION: Never rotate shaft of displacement sensor in respect to the outside body. This will permanently damage the sensor. During installation pull / push or pull shaft only axially. A pin has been provided at the end of displacement sensor that sits flush in a groove in sensor body. During assembly operation and while using spanners for tightening, keep sensor in closed position with pin seated inside groove such that no torque is exerted on its shaft and there is no rotational movement.

1.3 Conventions used in this manual

WARNING! Warning messages calls attention to a procedure or practice, that if not properly followed could possibly cause personal injury.

CAUTION: Caution messages calls attention to a procedure or practice, that if not properly followed may result in loss of data or damage to equipment.

NOTE: Note contains important information and is set off from regular text to draw the users' attention.

1.4 How to use this manual

The users' manual is intended to provide sufficient information for making optimum use of borehole extensometers in different applications.

To make the manual more useful we invite valuable comments and suggestions regarding any additions or enhancements. We also request to please let us know of any errors that are found while going through this manual.

NOTE: The installation personnel must have a background of good installation practices and knowledge of the fundamentals of geotechnics. Novices may find it very difficult to carry on the installation work. The intricacies involved in installation are such that even if a single essential but apparently minor requirement is ignored or overlooked, the most reliable of instruments will be rendered useless.

A lot of effort has gone in preparing this instruction manual. However the best of instruction manuals cannot provide for each and every condition in the field, which may affect the performance of the instrument. Also, blindly following the instruction manual will not guarantee success. Sometimes, depending upon field conditions, the installation personnel will have to consciously depart from the written text and use their knowledge and common sense to find the solution to a particular problem.

The manual is divided into a number of sections, each section containing a specific type of information. The list given below tells you where to look for in this manual if you need some specific information. It is however recommended that you read the manual from the beginning to the end to get a thorough grasp of the subject. You will find a lot of unexpected information in the sections you feel you may skip.

For description of vibrating wire borehole extensometers manufactured by Encardio-rite: See § 2.1 "Borehole extensometers".

For layout drawings of vibrating wire borehole extensometers: See figures 2.1 – 2.2.

For installation of single point borehole extensometers: See § 3 "Installation of single position borehole extensometer".

For tools & accessories required for installation: See § 3.4 "Tools & accessories required for installation".

2 BOREHOLE EXTENSOMETER (BHE)

2.1 General Description

Borehole extensometer (BHE) measures extension (displacement) that takes place with time in a bored hole or in several bored holes in a rock mass. The Encardio-rite BHE essentially consists of one anchor and a reference plate. Anchor is set in same borehole or in different boreholes drilled adjacent to first borehole. The BHE helps to accurately measure distance between anchor with respect to reference plate and thus monitor with passage of time their relative displacement in respect to each other. It is usually assumed anchor is in stable ground and so any change in anchor spacing is interpreted as sag of roof bed, movement of side wall or slope, settlement of foundation etc.

Model EDS-71V/P BHE is specially designed to monitor a relative displacement of a single anchor economically over any other borehole extensometer. At locations where access to mouth of borehole is easily available, mechanical measurement of displacement by model EDS-64U/D is economical and reliable. Displacement readings are taken by a micrometer depth gage by measuring depth of reference button at near end of connecting rod from a reference plate.

Model EDS-71V/P borehole extensometer basically comprises following major sub-assemblies:

- Reference head assembly
- Vibrating wire displacement sensor/ potentiometric sensor
- Connecting rod assembly (fibreglass or stainless steel AISI 410)
- Anchor (reinforced bar or packer)
- Grouting and vent tube as required

2.1.1 Reference head assembly

Refer to figures 2.1& 2.2 for details of single point BHE reference head assembly. Reference head assembly is supplied packed from factory as per items listed in figure 2.1. The sensor is separately supplied but it is very convenient to assemble it at site inside the reference head assembly along with the connecting rod ends according to instructions given in § 3.

The reference head assembly consists of a flanged housing (5), an adaptor cum guide plate (6) is fixed to the near end with help of M4x8 grub screws (8a). A grub screw M4x5 (8b) is provided in adopter cum guide plate to fix the sensor. The reference plate (14) is fixed to guide plate with an allen head screw M5x12 and one stainless steel centre pillar (13) in such a way that the holes marked (1,G,V) on reference plate is aligned to the respective holes of guide plate. The holes 1,G,V are used for connecting rod, grout and vent tube respectively. The removable cover (19) is threaded to the adopter cum guide plate (6) to protect the entire assembly.

2.1.2 Displacement sensor

The Encardio-rite model EDE-VXX/PXX linear displacement sensor is used in model EDS-71V/P borehole extensometer for transmitting the mechanical displacement to a remote observation room. It basically consists of a vibrating wire sensor having a stroke of 50 , 100 or 150 mm.

The retractable shaft of the sensor having a male thread of M6x12 is connected to the connecting rod through a link system. The sensor is provided with an integral 1 m long ϕ 4 mm four core cable with cores in red, black, green and white. Red and black cores are for frequency signal while green and white are for temperature monitoring through a thermistor.

Refer to data sheet 1085-03 P on model EDE-VXX vibrating wire linear displacement transducer (20) for detailed description and specifications.

The potentiometric sensor model EDE-PXX is used in place of vibrating wire sensor if required.

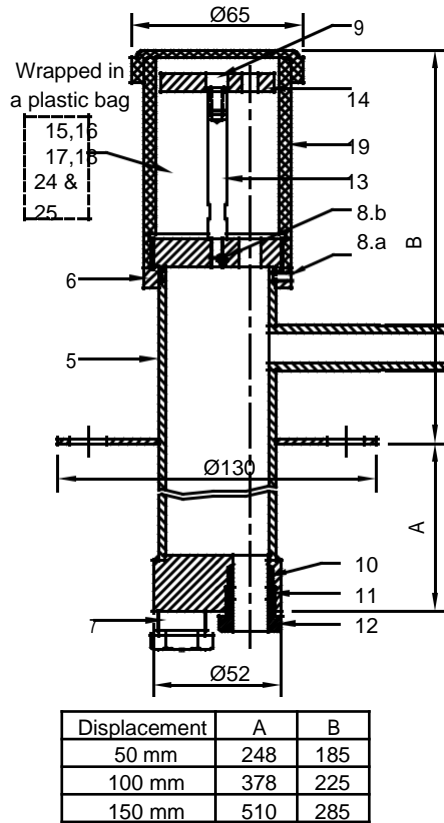

Figure 2.1 - Single point BHE reference head assembly

Item	Description
1	Anchor
2	Connecting rod
3	Vent tube
4	Grout tube
5	Flanged housing
6	Adaptor cum guide plate
7	Long hollow bolt
8.a	Grub screw, M4x8
8.b	Grub screw, M4x5
9	Allen head screw, M5x12
10	Rubber bush
11	Washer
12	Hollow bolt
13	Center pillar
14	Reference plate
15	Reference button
16	Link plate
17	Sensor tightening nut
18	Sensor lock nut
19	Cover
20	Displacement sensor
21	Expandable anchor
22	Nipple with chuck nut
23	Junction box assembly

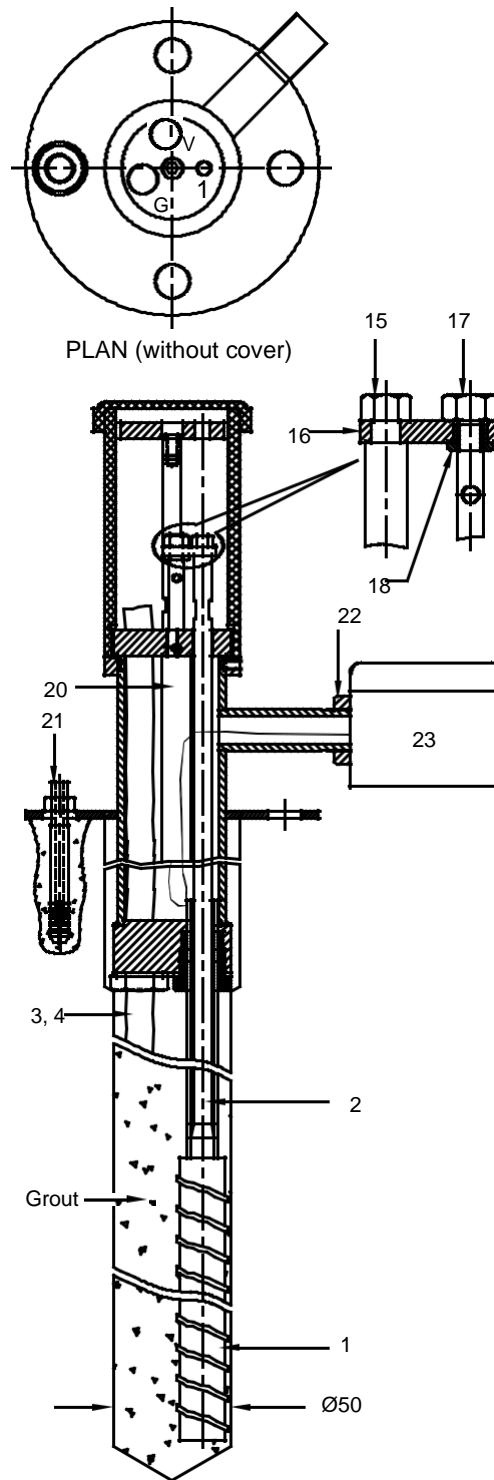

Figure 2.2 - Single point BHE detailed assembly

2.1.3 Connecting rod assembly

2.1.3.1 Fibreglass connecting rod assembly

Fibreglass connecting rod assembly (2) comprises of a fibreglass rod of specified length protected inside an outer continuous nylon tube. The rod has two end connectors. One end connector has a male thread and fits into anchor (1). Other end connector with a female thread is for connecting to reference button (15). Displacement of connecting rod end is transferred through a link plate (16) to the displacement sensor (20) with the help of a sensor-tightening nut (17) and a sensor lock nut (18). Components 15, 16, 17 and 18 are packed inside the reference head assembly in a plastic bag.

The fibreglass assembly is illustrated below in figure 2.3

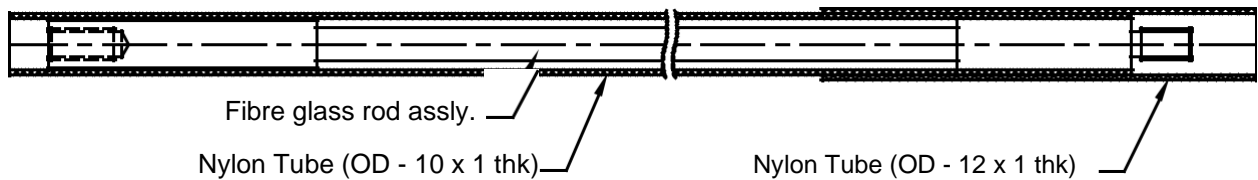

Figure 2.3 – Fibreglass connecting rod assembly

Anchor end of nylon tube is firmly sealed with anchor to prevent any grout from leaking in. Other end of nylon tube is firmly sealed in reference head assembly with help of rubber bush (10), washer (11) and hollow bolt (12) and long hollow bolt

Proper sealing in reference head assembly is especially necessary for upwards to horizontally slanting holes to prevent any grout leaking into reference head assembly during grouting.

The outer nylon tube allows free movement to fibreglass rod and reference button even after borehole is grouted.

NOTE: Fibreglass rods are generally more suitable for vertically upward holes as compared to downward holes. This is because in vertically upward holes the connecting rod is in tension; whereas in downward holes it is in compression, resulting in sagging or buckling. Longer the extensometer, greater may be the sagging or buckling.

Shorter the extensometer, better is accuracy of measurement of relative displacement between anchors. In deeper boreholes, use of stainless steel connecting rods is recommended, as they are more rigid.

Design Engineer should carefully consider what type of connecting rod to use taking into consideration field conditions and accuracy of measurement required. Actual performance of rods is determined by site conditions and it is recommended to conduct some field tests to arrive at a proper conclusion.

2.1.3.2 Stainless steel AISI 410 connecting rod assembly

Stainless steel AISI 410 connecting rods of 8 mm diameter are available in standard lengths of 1m, 2 m and 3 m with a M6 x 12 mm male thread at one end and a M6 x 15 mm female thread at other end. These are connected together at site for positioning anchor at the correct depth from mouth of borehole. Thread sealant Loctite 290 or equivalent is used between threads to firmly grip connecting rods to each other.

To give an example, in case depth of a particular anchor from the mouth is 14 m, use four connecting rods of 3 m length and one of 2 m length. Similarly, in case depth of anchor from the mouth is 25 m, use eight connecting rods of 3 m length and one connecting rod of 1 m.

On the near end of assembled connecting rods a standard 14 cm spacer with male thread on one side and female on the other side is always provided. The reference button (15) is threaded into the female end of this spacer. The male thread of connecting rod most distant from the mouth of the borehole fits into the anchor (1).

PVC tubing 14 mm od x 10 mm id in 3 m length is provided for enclosing connecting rods at time of assembly. One end of these tubes is swaged to form a male extender such that male and female ends of successive PVC tubes can be conveniently assembled to each other using any PVC jointing compound in-between. After jointing, the joint should always be checked by pulling and then wrapped with PVC tape to make it leak proof. The outer PVC tubing allows free movement to connecting rods and reference button even after borehole is grouted.

The furthest PVC tubing is firmly sealed to the anchor to prevent any leakage of grout into the PVC tube.. This 3 m long PVC tubing is cut by 50 mm from the plain end to make it convenient for successive connecting rods and PVC tubings to be connected together.

The near end of the PVC tubing is firmly sealed in flanged housing (5) with help of rubber bush (10), washer (11) and hollow bolt (12). The PVC tube should be cut such that when sealed in flanged housing, its face extends around 20 mm beyond rubber bush (10). Proper sealing in reference head assembly is especially necessary for upwards to horizontally slanting holes for preventing any grout for leaking into reference head assembly during grouting.

2.1.4 Anchor

2.1.4.1 Following type of anchors are available from Encardio-rite:

- Encardio-rite groutable anchors ϕ 20 mm x 500 mm long usually used for hard rocks. These are lowered down or pushed in borehole along with connecting rod of appropriate length and fixed in position by cement grout. The connecting rod is protected from cement grout by enclosing in plastic tubing, thus allowing for its free movement. Groutable anchors may also be installed in vertical boreholes or holes inclined upwards. Installation of groutable anchors in holes inclined upwards needs special precautions to retain grout and prevent it from flowing out of borehole.
- Encardio-rite packer anchors usually used for soft rocks and soil. These are lowered down or pushed in borehole along with connecting rod of appropriate length and fixed in position by pumping cement grout into the packer for taking a firm grip with the surroundings. Refer to consultant for use with fibreglass connecting rods.

NOTE: Encardio-rite uses convention that depth of anchor is calculated as distance from mouth of hole to near end of anchor.

2.1.4.2 Groutable anchor for fibreglass option



2.1.4.3 Groutable anchor for AISI 410 rod option (swaged end of PVC tube slides over it)

Figure 2.4

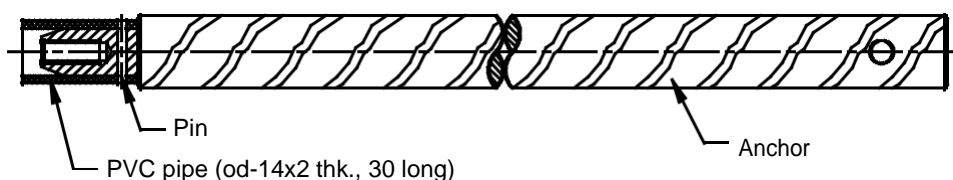

Figure 2.5

2.1.4.4 Packer anchor

Packer anchor with geotextile bladder inflated with grout is generally used in fractured rock or soil.

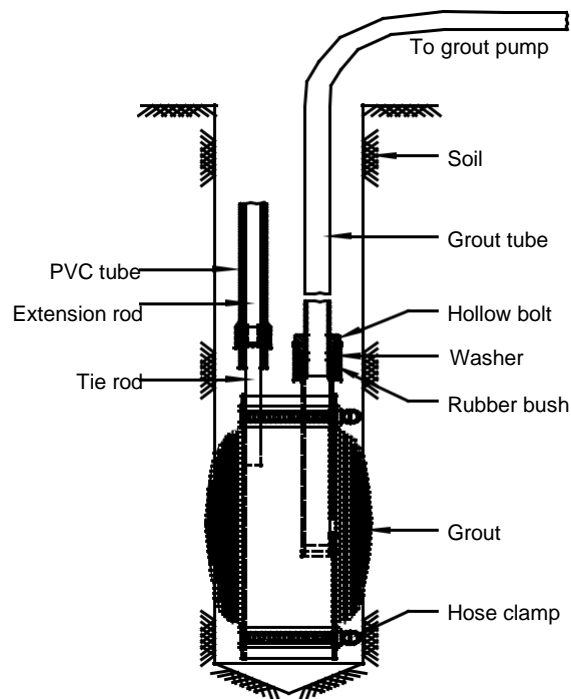

Figure 2-6

2.2 Accessories

2.2.1 *Junction box*

Cable can be extended from the sensor to the observation room. Alternatively a junction box is available for termination of cable from sensor and transmitting the signal through a multi-core cable to the observation room.

2.2.2 *Cable*

For range of cables available, refer to 'Accessories' in Consolidated Catalogue on <http://www.encardio.com>.

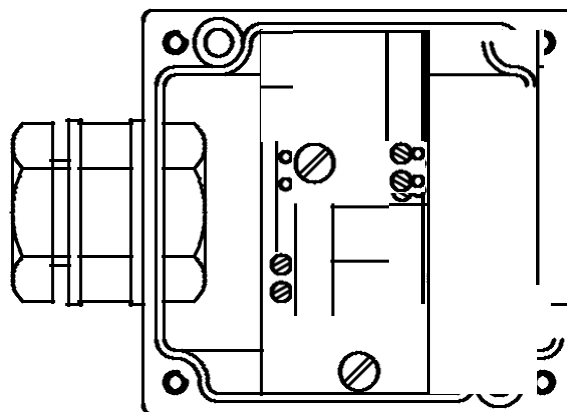

Figure 2.7- Junction box

3 INSTALLATION OF SINGLE POINT BOREHOLE EXTENSOMETER

NOTE: Procedure described below is for installing single point borehole extensometer with fibreglass connecting rods for in a downward sloping hole using groutable anchors. For installation in an upward to horizontally sloping borehole, or for using packer anchors, modify procedure suitably.

Due to many permutations and combinations in type of BHE required by users and widely varying conditions encountered from site to site, the procedure described is suggestive and may be used as a guide only. The installation personnel will have to use experience in devising the best method of installation.

3.1 Site preparation before installation

3.1.1 Drill hole of 50 mm diameter to a depth of 0.8 m more than specified length.

NOTE: In case borehole extensometer is to be mounted horizontally and design permits, it is desirable to provide a downward slope of 5° or more to borehole. This facilitates grouting of anchors as grout can easily flow in.

3.1.2 At mouth of borehole, increase diameter of drilled hole to 63 mm up to a depth of 300 mm for 50 mm displacement sensor or 425 mm for 100 mm and 560 mm for 150 mm displacement sensor. This is for wrapping outside of housing with rags or jute cloth strips soaked in cement during installation.

3.1.3 Insert reference head assembly centralised in the 63 mm borehole. Taking holes on flange as reference, drill four holes 12 mm diameter x 125 mm deep for fastening flange to borehole. Remove reference head assembly from borehole.

3.1.4 Wash hole clean up to bottom by pumping in fresh water.

3.2 Check sensor before installation

The cable from Vibrating wire sensor is four wired. Red and black cores are for frequency signal while green and white are for temperature monitoring through a thermistor. The cable from Potentiometric sensor is also four wired. Red and black cores are for (+) and (-) excitation while green and white are for (+) and (-) output. Check working of sensor as follows:

3.2.1 Connect sensor to portable indicator model EDI-51V (for vibrating wire sensor) and EDI 53P (for Potentiometric sensor). With displacement shaft in retracted position enter sensor constants from Test Certificate and set reading in engineering units at zero mm.

NOTE: Data entry of sensor constants in the EDI-51V/ EDI 53P will later on be used to set sensor in flanged housing during installation process.

3.2.2 Using a scale, move the shaft by about 25 mm. The indicator should read around 25 mm. This change in reading ensures proper functioning of displacement sensing system. The sensor can now be installed in the housing assembly (5) when required.

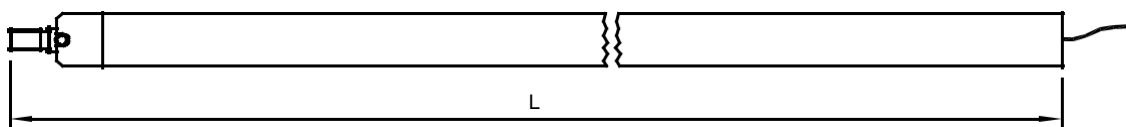

Figure 3.1 – Displacement sensor

Displacement (mm)	V W sensor – L in mm.	Potentiometric. sensor – L in mm.
50	290	325
100	420	425
150	550	525



Encardio-rite Electronics Pvt. Ltd.

A-7 Industrial Estate, Talkatora Road, Lucknow, UP-226011 India

E-mail: sales@encardio.com, encardio@sancharnet.in; Website: www.encardio.com

Tel. +91 (522) 2661039/40/41/42 Fax +91 (522) 2661043



TEST CERTIFICATE

Customer ABC Corporation
 PO # PHP 050-05 October 28, 2005
 V.W Displacement sensor for Bore hole
 Instrument Extensometer
 Serial number 05508 Date 09.11.2005
 Range 50 mm Temperature 5
 e 25°C

Input Displacement (mm)	Observed value			Average (Digit)	End Point Fit (mm)	Poly Fit (mm)
	Up1 (Digit)	Down (Digit)	Up2 (Digit)			
0.00	2297.4	2294.0	2294.0	2296	0.00	0.00
10.00	3437.8	3432.1	3432.1	3435	10.08	10.00
20.00	4570.7	4567.8	4567.8	4569	20.12	20.01
30.00	5700.8	5695.9	5695.9	5698	30.11	30.00
40.00	6824.1	6821.4	6821.4	6823	40.05	39.99
50.00	7947.7	7947.7	7946.0	7947	50.00	50.01
Error (% fs)					0.23	0.03

Digit $f^2 \times 10E-3$

Linear gage factor (G) 8.848E-03 mm/digit

Thermal factor(K) -0.003 mm/°C

Polynomial constants A=1.4276E-08 B=8.7037E-03 C=01 2.0061E+

Displacement "D" is calculated with the following equation:

Linear $D(\text{mm}) = G(R_1 - R_0) - K(T_1 - T_0)$

Polynomial $D(\text{mm}) = A(R_1)^2 + B(R_1) + C - K(T_1 - T_0) - D_0$

R_1 = current reading & R_0 is initial reading in digit.

D_0 = Initial reading in mm

Zero reference (initial position) in the field must be established by recording the initial reading R_0 (digit) along with temperature T_0 (°C) just after installation.

Note Zero displacement reading given in above calibration chart is taken at 3 mm from mechanical ZERO

Pin configuration/wiring code:

Red & black Signal

Green & white Thermistor



Encardio-rite Electronics Pvt. Ltd.

A-7 Industrial Estate, Lucknow, UP-226011 India

E-mail: sales@encardio.com, encardio@sanchamet.in; Website: www.encardio.com



Date : 15.12.2008

Customer :
 P.O.no. :
 Instrument : Potentiometric displacement sensor
 Model : EDE-P05
 Serial number : XXXXX
 Range : 50 mm

Input Displacement (mm)	Observed value Up1 (Volts)	Observed value Up2 (Volts)	Average (Volts)	Calculated displacement (mm)	Error % FS
0.00	0.0550	0.0580	0.0565	0.00	0.00
7.00	0.3250	0.3260	0.3255	6.95	0.11
17.00	0.7150	0.7140	0.7145	16.99	0.01
27.00	1.0990	1.0990	1.0990	26.92	0.16
37.00	1.4870	1.4870	1.4870	36.95	0.11
48.00	1.9150	1.9150	1.9150	48.00	0.00

Max error (%FS) : 0.16

Linear gage factor (G) : 25.83 mm/Volts

Displacement "D" is calculated with the following equation:

Linear : $D(\text{mm}) = G(R1 - R0)$

R1 = current reading & R0 is initial reading in Volts

Zero reference (initial position) in the field must be established by recording the initial reading R0 (Volts) just after installation.

- Note** :
- 1) Zero displacement reading given in above calibration chart is taken at around 3 mm from mechanical zero.(slider fully in).
 - 2) For best linearity use the displacement transducer only upto 3 mm from its mechanical displacement limits (ends)

Pin configuration/wiring code:

Red : Excitation '+ 5 V DC'
 Black : Excitation 0 V
 white : Output high (0 - 2 V DC)
 Green : Output 0 V

Checked by

Tested by

CAUTION: Never rotate shaft of displacement sensor in respect to the outside body. This will permanently damage the sensor. During checking pull / push shaft only axially. A pin has been provided at end of displacement sensor that sits flush in a groove in sensor body.

3.3 Procedure

3.3.1 Refer to figure 2-1 and 2.2. Remove cover (19) and take out polythene bag that contains requisite quantity of reference buttons (15), link plates (16), sensor tightening nut (17), locknuts (18), M6 x 100 or 125 mm or 150 mm cheese head screw (24) depending upon type of housing and locking nuts (25).

3.3.2 Remove guide plate (6) with 2 mm Allen key and hollow bolts (12) from holes marked 1, G and V from flanged housing (5) and place latter flat on clean ground around 1 m away from borehole.

CAUTION: Always mark a line between flanged housing (5) and adopter cum guide plate (6) before dismantling so that it can be aligned properly while assembling the sensor (20).

3.3.3 Cut grout and air vent tubes (Φ 12 mm outside dia.x 1 mm thick supplied in coil form) to required length. Generally, lower end of grout tube is kept at a level higher than anchor. Grout should cover anchor to mouth or be around 1 m from face of borehole whichever distance is less. To determine length of grout tube, ensure that around 1.5 m is required outside the reference plate (14) for ease in attaching it to grout pump. Air vent tube should be projected around 0.3 m is outside reference plate (14). Lower end of air vent tube should always be at a higher level than lower end of grout tube. While inserting anchor in borehole, lowest end of grout tube is tied with a cable tie to the connecting rod

NOTE: In upward to horizontally sloping borehole, grout tube should be about 2 m longer than specified depth of anchor and taped around 100 mm below far end of anchor. Tape grout tube every 2 m with a PVC tape to plastic tube of connecting rod assembly to prevent it from swinging loose.

NOTE: In upward to horizontally sloping borehole, air vent tube should be about 1.5 m longer than specified depth of anchor and taped around 100 mm above far end of anchor. Tape air vent tube every 2 m with a PVC tape to the nylon tube of connecting rod assembly to prevent it from swinging loose. Top end of air vent tube should be at a level higher than anchor.

CAUTION: In upward to horizontally sloping borehole, care should be taken that air vent tube is taped around 100 mm beyond rear end of anchor and should not get detached. This is very necessary for the grout to fill in up to end of anchor.

3.3.4 Guide grout tube through hollow bolt (12), washer (11) and rubber bush (10) of hole marked G at bottom of flanged housing and corresponding holes on guide plate (6) and reference plate (14), the grout tube is around 1.5 m outside the reference plate. Similarly, guide the air vent tube through hollow bolt of hole marked V at bottom of flanged housing; the vent tube is around 0.3 m outside the reference plate (14).

3.3.5 Tighten corresponding hollow bolt (12) with spanner size 21 mm and long hollow bolt (7) to firmly grip nylon grout and air vent tubes but not to squeeze them.

CAUTION: Always tight hollow bolts (12) 2 nos. firstly and then long hollow bolt (7) at the end.

CAUTION: In upward to horizontally sloping borehole, be particularly careful in tightening the hollow bolts (12) properly as grout may leak through into the reference head assembly during the grouting

process.

- 3.3.6 Screw male end connector of fibreglass rod assembly (2) to groutable anchor (1). In the process, the nylon tubing will also get firmly gripped to groutable anchor. A little grease may be used for ease in assembly.
- 3.3.7 Lower groutable anchor into borehole till near end of fibreglass rod is remaining around 1 - 1.5 m outside face of borehole. Trim nylon sleeve such that female connector and fibreglass rod is exposed by around 100 mm from connector end.

WARNING! Fibreglass rod is supplied in coil form using cable ties. It is very stiff material and must be carefully handled when unwinding as the end may snap back and cause personal injury.

- 3.3.8 Guide end of fibreglass rod through hollow bolt (12), washer (11) and rubber bush (10) of hole marked '1' at bottom of flanged housing (5) and corresponding holes on guide plate (6) with end protruding around 80 mm from guide plate (6) face. To do this the fibreglass rod will have to be bent. Tighten hollow bolt on connecting rod such that it does not slip into the borehole.

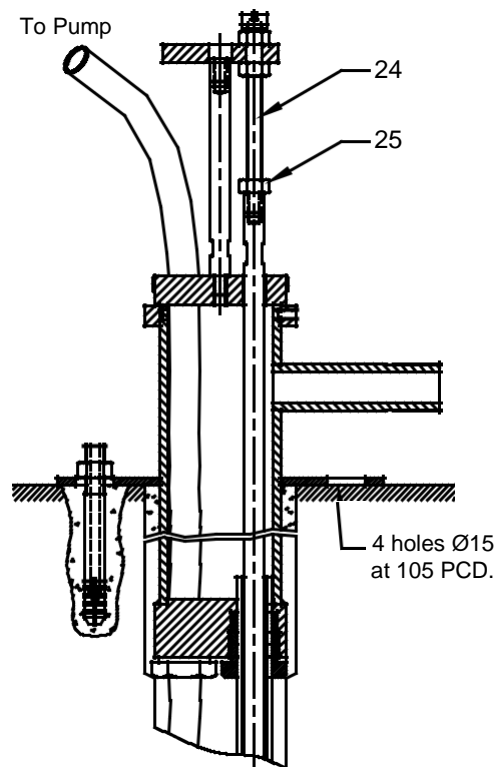

Figure 3.2 – Setting arrangement for 1 point BHE

Item	Description
24	M6 x 100 mm or 125 mm or 150 mm cheese head screw
25	M6 lock nuts – 3 nos. per cheese head screw

NOTE: Holes on top of flanged housing are marked clockwise with identification numbers 1, G respectively and V in middle. As an Encardiorite convention, serial number '1' always corresponds to anchor.

As an additional precaution, make a note in a diary of orientation of serial number '1' with geographical North.

NOTE: When BHE is installed on a side wall or roof, extension is generally expected. In such a case, it may be desirable to set connecting rod end as close as possible to reference plate (14). Similarly, when BHE is installed in a vertically down borehole settlement is generally expected. In such cases, it may be desirable to set connecting rod end as close as possible to guide plate (6). In other cases, it may be necessary to set connecting rod end in middle such that either compression or tension can be monitored.

In other words, if only compression is expected, set zero reading of sensor by extending shaft by around 10 mm. If only extension is expected, set zero reading of sensor by extending shaft by around 10 mm less than sensor range. If required, sensor may be set in mid position. As a precaution, never set the sensor at the very end.

Sensor range (A)	Setting range (B)	Shaft end from guide plate top (C)
50 mm	± 25 mm	45 mm
100 mm	± 50 mm	70 mm
150 mm	± 75 mm	95 mm

A set of 100 mm or 125 mm or 150 mm long cheese head screws (24) and lock nuts (25) is provided for this purpose.

3.3.9 For any other required range, set distance 'C' accordingly. For example, Assemble cheese head screw (24) and locking nuts (25) as shown in figure 3.2. Slightly loosen hollow bolts (12) related to hole '1'. Adjust end of connecting rod in required position and tighten the lock nuts (25). To set connecting rod ends, refer to table above.

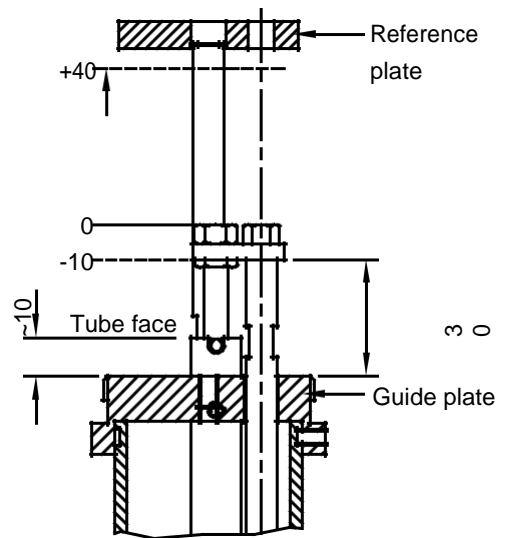

Downward borehole

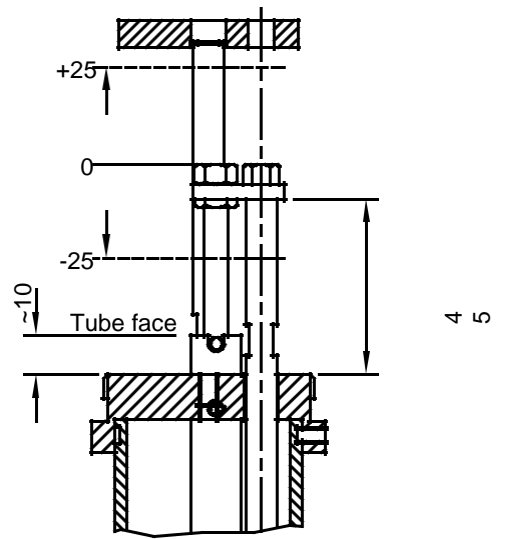

Mid position borehole

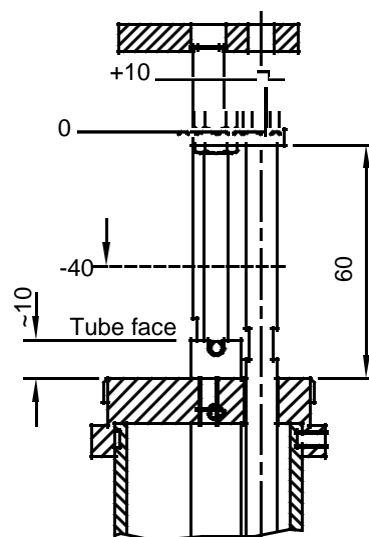

Upward borehole

3.3.10 When installing a BHE with 50 mm displacement in a vertically downward borehole, settlement is expected and setting range specified may be $-10/+40$ mm. In such a case connecting rod end distance from guide plate top (6) should be set at $(45 - 15)$ i.e. 30 mm.

NOTE: If readout unit shows negative displacement reading, movement of structure is away from borehole face and vice versa.

3.3.11 Re-assemble adopter cum guide plate (6) with grub (8.a) and (8.b) taking care that holes marked '1' 'G' and 'V' are aligned in reference plate (14), adopter cum guide plate (6) and flange housing (5).

3.3.12 Tighten hollow bolts (12) with spanner size 21 mm and long hollow bolt (12) to firmly grip nylon tube but not to squeeze or hinder free movement of female end connector inside the nylon tube.

NOTE: In upward to horizontally sloping borehole, tighten hollow bolts (12) particularly carefully as grout may leak through into the reference head assembly during the grouting process.

NOTE: Take care that extensometer assembly does not drop into borehole accidentally. It is advisable to secure it properly by attaching a safety rope to the anchor.

3.3.13 Wrap rags or jute cloth strips soaked in quick setting cement water mix outside flanged housing (5) to build up approximately 5 mm thick layer. Lift and insert housing in borehole using a to and fro screwing motion sealing the annular space between housing and borehole.

3.3.14 Fix expandable anchors (21) in holes drilled earlier for securing flanged housing with the M12 nuts and washers provided. Give enough time to let flanged housing set in borehole.

3.3.15 Connect grout pipe to grouting machine or pump, grout till the entire cavity is filled and grout flows out of air vent pipe. Be very careful that grout flowing out of air vent tube does not get into the flanged housing and makes the installation messy.

3.3.16 Pump clean water through the grout tube till clear water comes out of air vent tube. This will keep the grout tube clean for topping up the grout later on.

NOTE: Give sufficient time for grout to set.

CAUTION: Clean up grout and air vent tubes with clean water after grouting operation is complete as in § 3.3.16 above

NOTE: Check Engineer for cement water proportion to be used in grout. Composition of grout to be used depends upon site conditions. In case of hard rock, 50 kg of cement with 30 kg of water has been successfully used at some project sites.

NOTE: Grout should cover anchor closest to the mouth or be around 1 m from the face of borehole whichever distance is less. This can be checked by inserting a ϕ 3 mm wire into borehole through vent pipe.

CAUTION: Please ensure that no grout overflows into the flanged housing. In case it overflows, it may get into the protective nylon tubing and jam the setting rods.

3.3.17 Again pump grout into the system after setting period of grout is over to ensure that all anchors are properly grouted. During setting, heavier grout has a tendency to settle down leaving water at top with a possibility that anchor is not properly grouted. Rule this possibility out by pumping in grout again and ensuring that any such water at the top is pumped out through the air vent tube and replaced by grout.

CAUTION: To get correct displacement readings, ensure that anchor is properly grouted. This problem may be particularly faced in case of anchor in downward boreholes and in upward holes where with cement in grout settling down, there may only be water around the anchor.

- NOTE:** For very deep hole, staged grouting may be necessary. It is always best to consult grouting engineer at site and take his advice
- NOTE:** Packer anchor does not require the borehole to be fully grouted. It is recommended to use a hand grout pump for better control. It is important to pump water first to water saturate packer geotextile sufficiently. Pump grout until pressure builds up sufficiently to around 400 to 500 kPa. Let pressure dissipate for a few minutes and then pump again till a distinct pressure is felt. Recommend grout mixture is 1 part cement and 1 part water by weight. Kink and tape grout tube to retain pressure and disconnect pump. Clean pump thoroughly.
- 3.3.18 Remove screws (24) and lock nuts (25). Remove reference plate (14) and centre pillar (13) Cut and remove grout and vent tubes. Round edges of grout and vent tube with a hand file. Clean reference head assembly properly. Reassemble reference plate with centre pillar to guide plate.
- 3.3.19 Remove guide plate (6).
- 3.3.20 Insert sensor (20) in flanged housing (5) taking care that the cable is carefully routed out to be eventually connected to the junction box (23). Secure sensor to adopter cum guide plate (6) with grub screws (8a) ensuring that tube face (refer to figure 3.1) is around 10 mm extended from face of adopter cum guide plate (6).
- NOTE:** Since only one sensor is being used therefore cable identification mark tagging is not required. Pull shaft of sensor and assemble to connecting rod end with reference button (15), link plate (16), sensor tightening nut (17) and locknut (18).
- 3.3.21 Screw in the sensor to connecting rod clearly noting position of extensometer '1'.
- CAUTION:** Never rotate shaft of displacement sensor in respect to the outside body. This will permanently damage the sensor. During installation pull or push or pull shaft only axially. A pin has been provided at the end of displacement sensor that sits flush in a groove in sensor body. During assembly operation and while using spanners for tightening, keep sensor in closed position with pin seated inside groove such that no torque is exerted on its shaft and there is no rotational movement.
- CAUTION:** Do not use thread sealant on any thread while mounting the sensor as it may have to be replaced at a later date.
- 3.3.22 Check displacement reading of sensor with model EDI-51V/EDI 53P read-out. Reading would be around specified initial reading (refer to § 3.3.11). Set reading precisely by loosening respective sensor with grub screws (8.a), repositioning sensor in adopter cum guide plate (6) and again tightening grub screw.
- 3.3.23 Reset zero reading in EDI-51V/EDI 53P to final set position of sensor. Subsequent readings will determine relative displacement between anchor and reference plate.
- 3.3.24 Take initial readings with help of depth micrometer. It is recommended to note date, time and temperature while taking the initial reading.
- NOTE:** A proper record of depth readings with depth micrometer should be permanently maintained. This is very important because sometimes it becomes necessary to verify the data from electronic sensors.
- 3.3.25 Attach nipple (22) to socket of flanged housing and fix junction box assembly (23) with cable from sensor routed to junction box.
- 3.3.26 Connect leads to respective connector pins in junction box.
- NOTE:** For transmitting signals to observation room, 4 core, 6 core, 12 core or 20 core cables are available from Encardio-rite.

3.3.27 Replace cover (19) over guide plate (6).

NOTE: Model EDS-71V/P BHE can be used as a mechanical system in case electronic measurement is not required. In such a case, BHE is installed without the electronic sensor. Later on, in case in some of the installations continuous monitoring is required, the electronic sensor can be installed at a later date.

3.4 Tools & accessories required for installation

The following tools and accessories are required for proper installation of the multi position borehole extensometer:

- 3.4.1 Soldering iron 25 watt
- 3.4.2 Rosin 63/37 solder wire
- 3.4.3 Thread sealant (Loctite 290 or equivalent)
- 3.4.4 Cable jointing compound
- 3.4.5 Acetone (commercial)
- 3.4.6 Spanner 6, 8, 10, 18, 21,22,24, 30 and 25
- 3.4.7 Allen key 2, 4
- 3.4.8 Screw driver (tip size 6 x 0.8 and 3 x 0.5 mm)
- 3.4.9 Phillips head screw driver (tip size 2 mm)
- 3.4.10 Hacksaw with 150 mm blades
- 3.4.11 Cable cutter
- 3.4.12 Wire stripper
- 3.4.13 Insulated pliers 165 mm
- 3.4.14 150 mm flat file
- 3.4.15 Toothbrush
- 3.4.16 Wire brush
- 3.4.17 Cloth for cleaning (lint less)
- 3.4.18 Cello tape/Insulation tape
- 3.4.19 Micrometer depth gage 100 mm range
- 3.4.20 Digital indicator model EDI-51V
- 3.4.21 Digital multi-meter