

NOVARENT

LOCATION ET VENTE DE MATÉRIEL DE MESURE

SINGLE POINT BOREHOLE EXTENSOMETER

MODEL EDS-71V/EDS-71M



OVERVIEW

The Encardio-rite model EDS-71V/EDS-71M single point borehole extensometer is a precision instrument designed to help civil engineers and geologists in the measurement of deformation of rock mass and adjacent or surrounding soil.

Together with anchor bolt load cell, it is an essential equipment for investigation and monitoring of foundations, slopes & embankments and for studying the behavior of rock around underground cavities, tunnels and mines. The borehole extensometer is an important instrument especially in investigation of underground cavities and landslides.

APPLICATION

- To determine how the roof or wall of a mine, underground cavity or tunnel behaves during excavation operation & to study the effectiveness of the support system.
- To predict potential roof or wall fall before it actually occurs. Roof or wall fall in an underground cavity is almost invariably preceded by measurable sag as the strata opens up and the movement usually occurs at an increasing rate as fall conditions are approached. Unsuspected roof and wall fall conditions are approached. Unsuspected roof and wall fall may result in serious accidents and may require costly patch-up and repair operations.
- To measure and monitor the movement in a slope or foundation due to excavation of underground cavities or due to the construction of a heavy structure like concrete, rock fill, masonry or earth dam over the foundation.

www.novarent.fr

0973791595

contact@novarent.fr

DESCRIPTION

The borehole extensometer measures extension (displacement) that takes place with time in a bored hole or in several bored holes in a rock mass. The single point borehole extensometer consists of a single anchor and a reference. They help to accurately measure distance between the anchors with respect to the reference and monitor its relative displacement with passage of time. It is usually assumed that the anchor is in stable ground and so any change in the anchor spacing is interpreted as sag of the roof bed, movement of side wall or slope, settlement of the foundation etc.

EDS-71V ELECTRONIC EXTENSOMETER

The model EDS-71V single point borehole extensometer incorporates vibrating wire transducer for measurement of displacement. A groutable reinforced bar anchor (1) is attached to fiber glass (2.a) or AISI 410 stainless steel (2.b) connecting rod of appropriate length, as specified in the design. Fiber glass connecting rod is supplied from factory in single length. The connecting rod is enclosed inside heavy duty protective tubing to allow for free movement. The displacement sensor is coupled to the connecting rod using link plate and lock nut.

Mounting details of the sensor is shown in detail. The system is rugged & is protected by a heavy duty cover. EDS-71V can be ordered from the factory for monitoring settlement at single depth. Spacer adjustment provided optionally for movement. It is suitable for a 2" dia (~50 mm) borehole for single point.

To house the head assembly, the diameter at the mouth of the borehole is increased to 62 mm more than the range in case of heave/settlement.

EXTENSOMETER ASSEMBLY

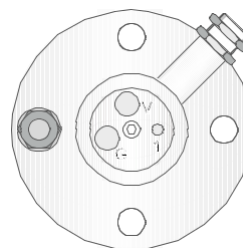

PLAN (without cover)

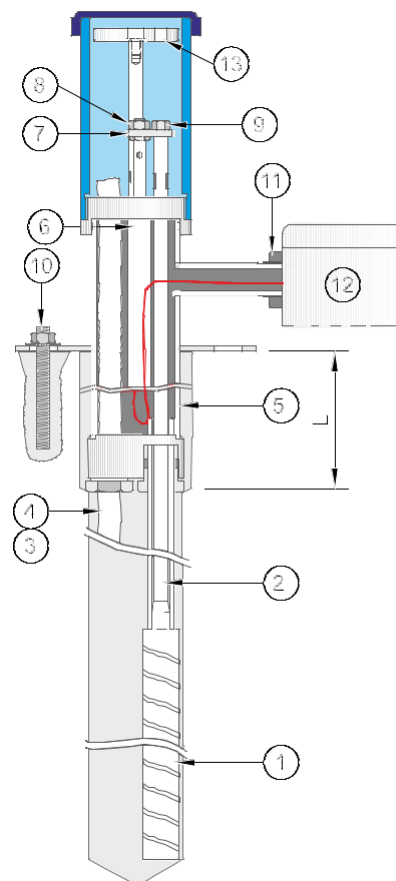

SI #	Description	Qty	SI #	Description	Qty
1.a	Anchor for fiber glass rod	1	9	Reference button	1
1.b	Anchor for stainless steel rod	1	10	Expandable anchor	4
2.a	Fiber glass connecting rod (Ø 6.3 mm) assembly with PVC protective tube (o.d.-14 mm x 2 mm thick)	#	11	Chuck Nut	2
2.b	SS connecting rod (Ø 8 mm) with PVC tube (o.d.-14 mm x 2 mm thick)	#	12	Junction box assembly	1
3	Air vent tube (o.d.-12 mm x 1 mm thick)	•	13 ■	Reference plate with mounting accessories	1
4	Grout tube (o.d.- 12 mm x 1 mm thick)	•	#	Quantity depends upon number of positions and depth of anchors	
5	Reference head assembly	1	•	Length varies from application to application	
6	Electronic displacement sensor	1	■	For use with model EDS-71M only	
7	Link plate	1		ØA - 50 mm and ØB - 62 mm	
8	Lock nut	1		L = for 50 mm sensor - 255 mm. 100 mm sensor - 385 mm.	

Vibrating wire sensor

Model EDE-VXX-RC series of vibrating wire linear displacement sensor is suitable for borehole extensometer. It is based on vibrating wire technology, having a stroke of 50 mm (EDE-V05), 100 mm (EDE-V10) or 150 mm (EDE-V15). The sensor converts mechanical displacement to an electrical output in frequency form.

The frequency output can be accurately measured by any vibrating wire readout unit. The data can also be automatically collected at desired frequency, stored and transmitted to remote server by a suitable datalogger.

The initial reading of the sensor is taken as the base. Subsequent readings are then compared with the initial reading to determine the magnitude of change in displacement across the opening.

For further details on vibrating wire displacement sensor refer to our datasheet # 1085.

EDS-71M MECHANICAL EXTENSOMETER

Model EDS-71M mechanical single point borehole extensometer is available for taking reading with a mechanical dial gage.

EDS-71M mechanical borehole extensometer is supplied without the vibrating wire sensors. However, it has a provision to take readings electronically at a later date, by installing vibrating wire displacement sensors in the housing.

SPECIFICATIONS

Model	EDS-71V
Range (mm)	50, 100, 150
Accuracy	± 0.2 % fs normal ± 0.1 % fs optional
Sensitivity	± 0.02 % fs
Non linearity	± 0.5 % fs
Temperature limit	- 10° to 80°C (operational)
Thermistor	YSI 44005 or equivalent (3 kOhms at 25°C)

ORDERING CODE & INFORMATION

EDS-71 M/V-XY -NNN

